

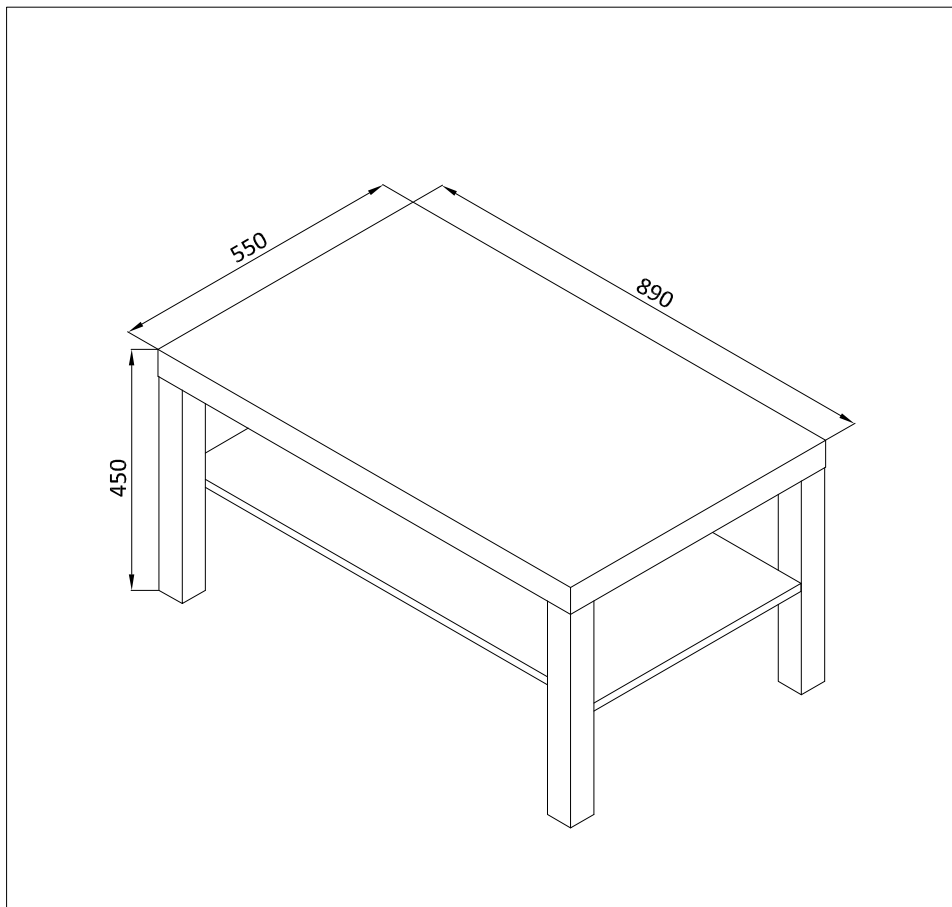

ASSEMBLY INSTRUCTION
PIPPA COFFEE TABLE
ITEM CODE 44992

Imported by Amart Furniture Pty Ltd, Qld, Brisbane Australia.
For any assistance with assembly or for missing parts please phone
Amart Furniture Ewing Road, Customer Service Free call 1800 351 084



Imported by Amart Furniture Pty Ltd, Qld, Brisbane Australia
For any assistant with assembly or for missing parts please phone
Amart Furniture Ewing Road, Customer Service Free call 1800 351 084

PRE- ASSEMBLY PREPARATION

Before you start:

1. Choose a clean, level, spacious assembly area. Avoid hard surfaces that may damage the product.
2. Take care when lifting. Product should be assembled as near as possible to the point of use.
3. Ensure that you have all required contents for complete assembly.
4. Always read the assembly instructions carefully before beginning assembly.
5. Keep all hardware parts and packaging out of reach of small children.
6. Do not over tighten the screws and bolts as this may damage the threads.

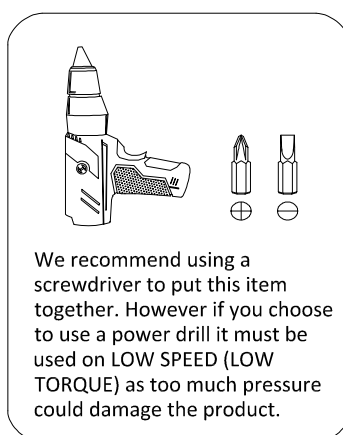
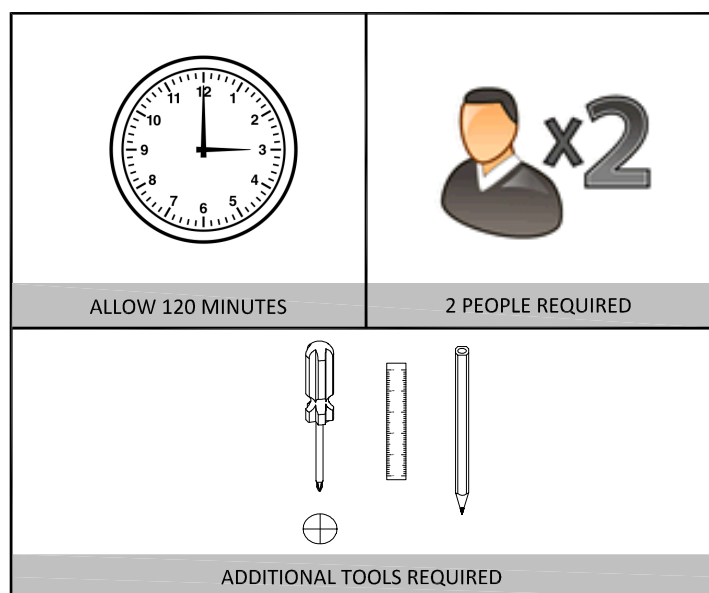

PARTS LIST

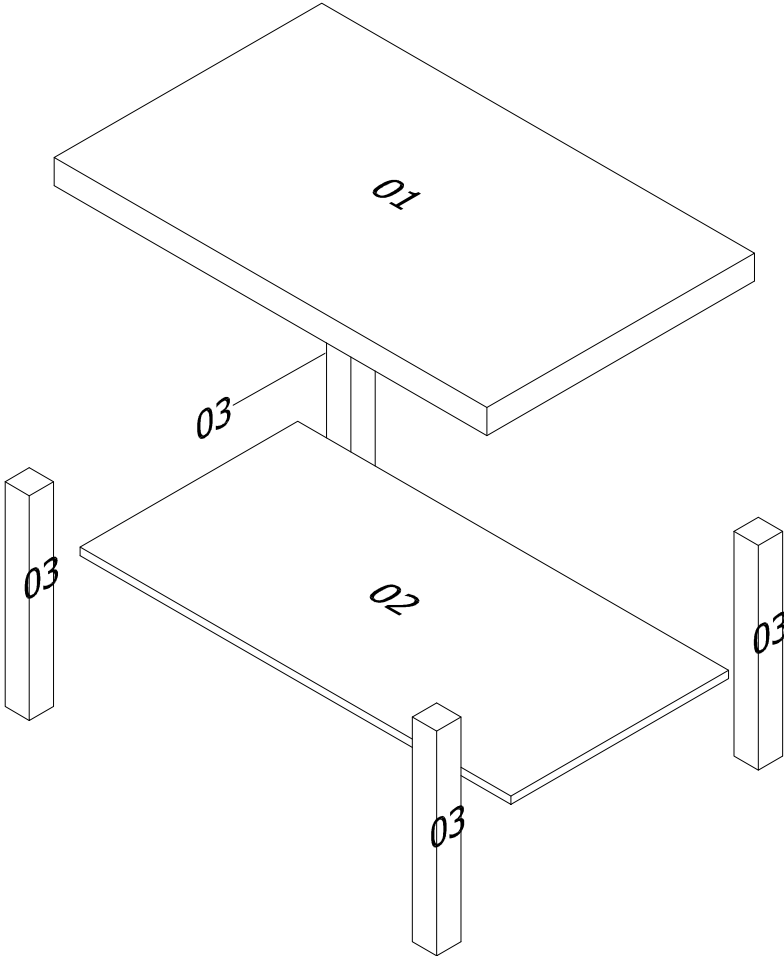

01	TOP PANEL	X1
02	SHELF PANEL	X1
03	LEG PANEL	X4

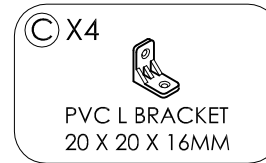
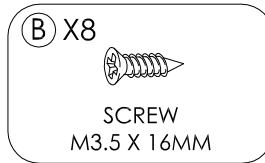
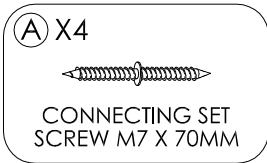

STEP 1:

Insert the connecting set screw (A) to panel (1) as shown.

(A) X4

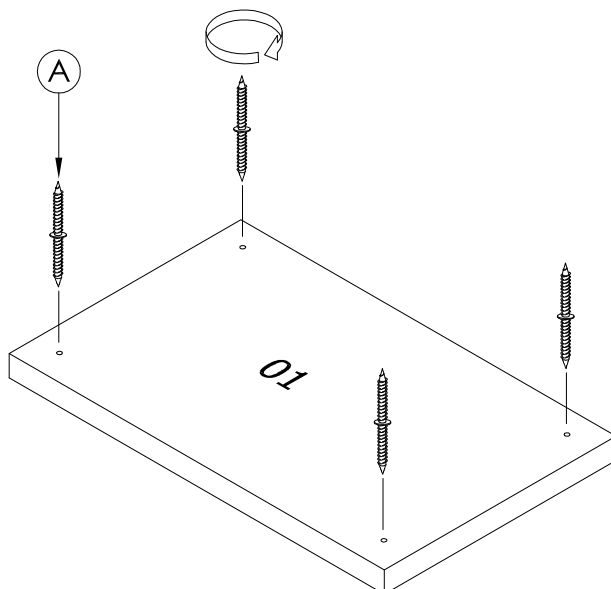

STEP 2:

Turn leg panel (3) into another side of screw (A) as shown.

NOTE:Please ensure care is taken not to overtighten the legs, as overtightening may cause the leg to crack.

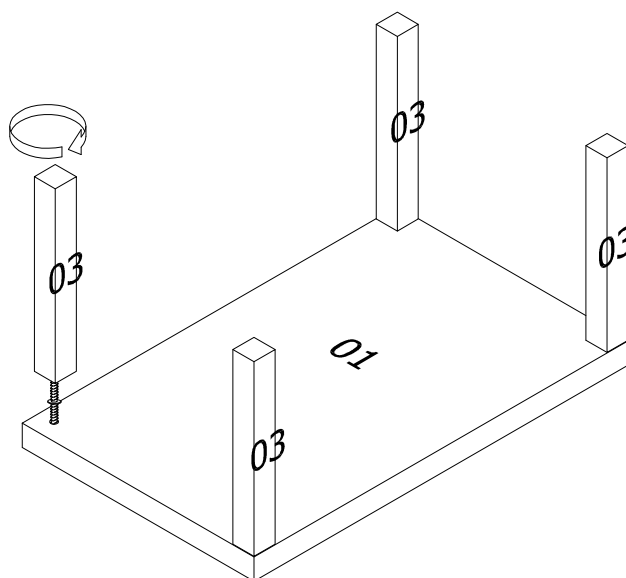

STEP 3:
Use pen and marking.

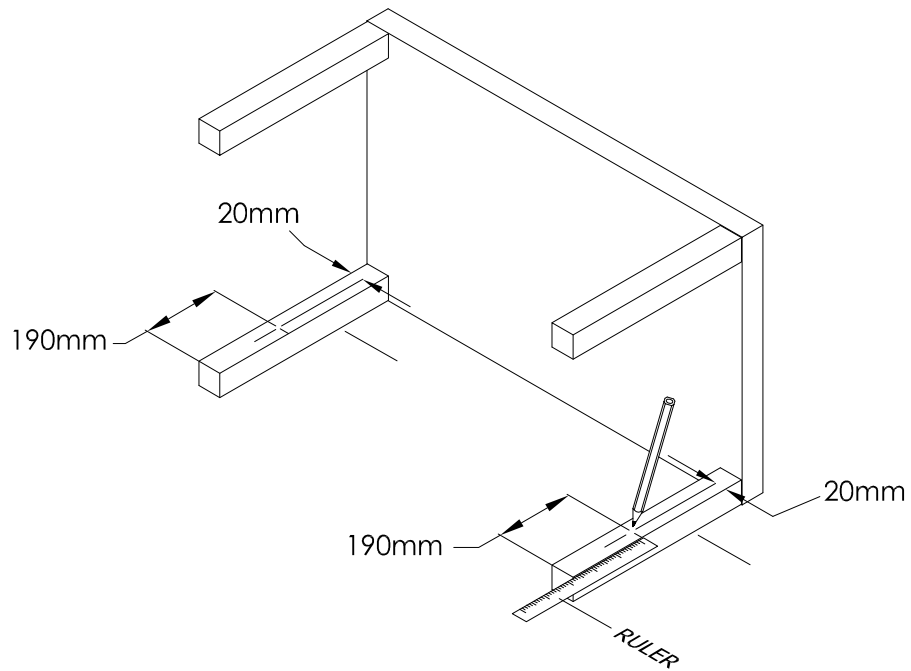

STEP 4:
Attach the bracket (C) to leg panel (3) using screw 16mm (B).

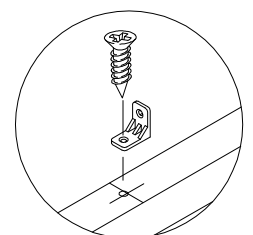
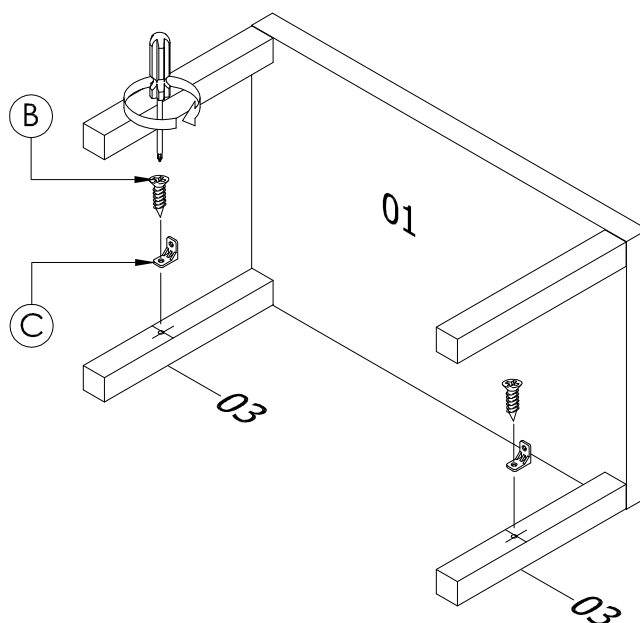
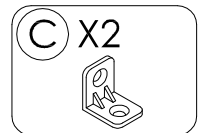
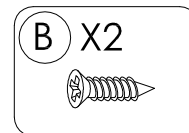

STEP 5:
Use pen and marking.

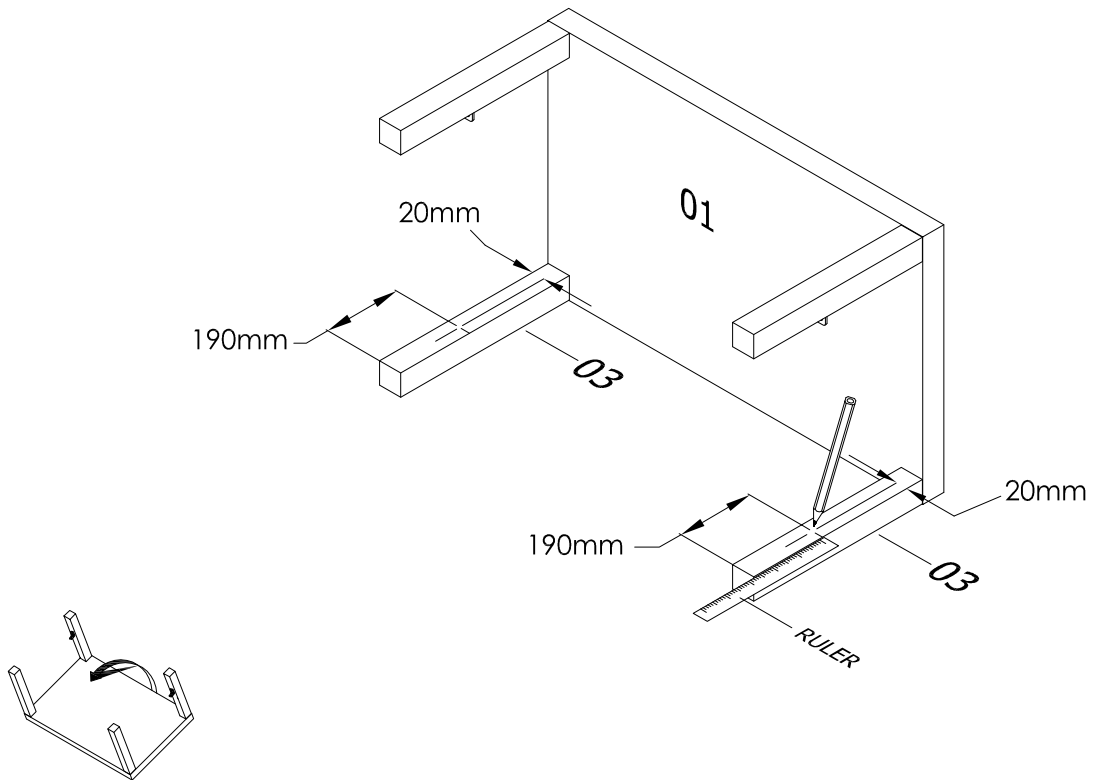

STEP 6:
Attach the bracket (C) to leg panel (3) using screw 16mm (B).

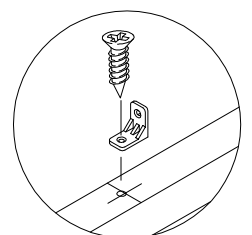
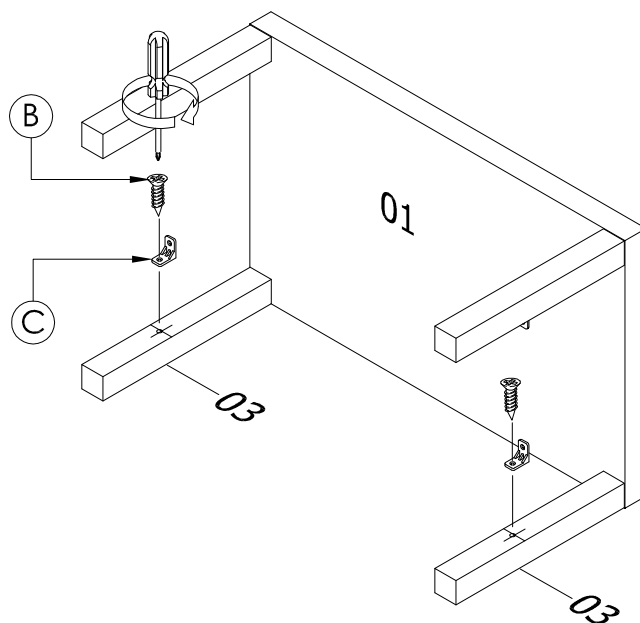
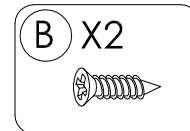

STEP 7:
Put the shelf panel (2) into the table.

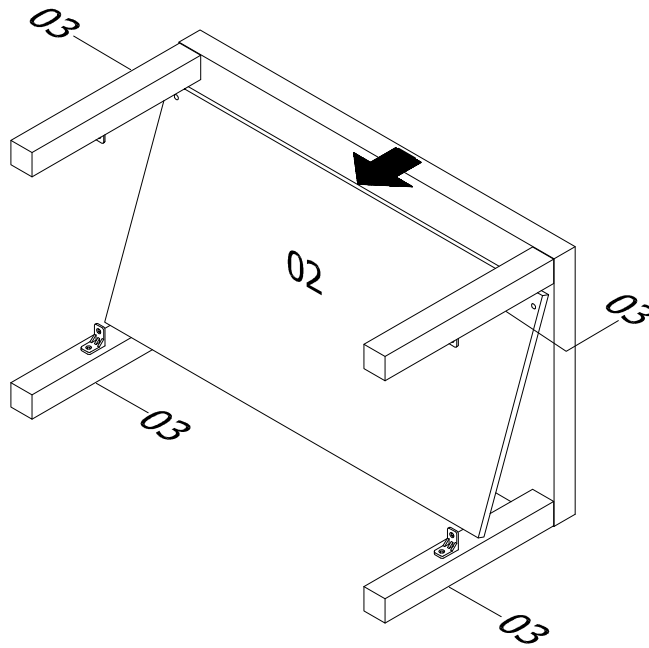

STEP 8:
Affix the shelf panel (2) using screw 16mm (B) as shown.

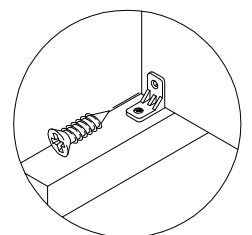
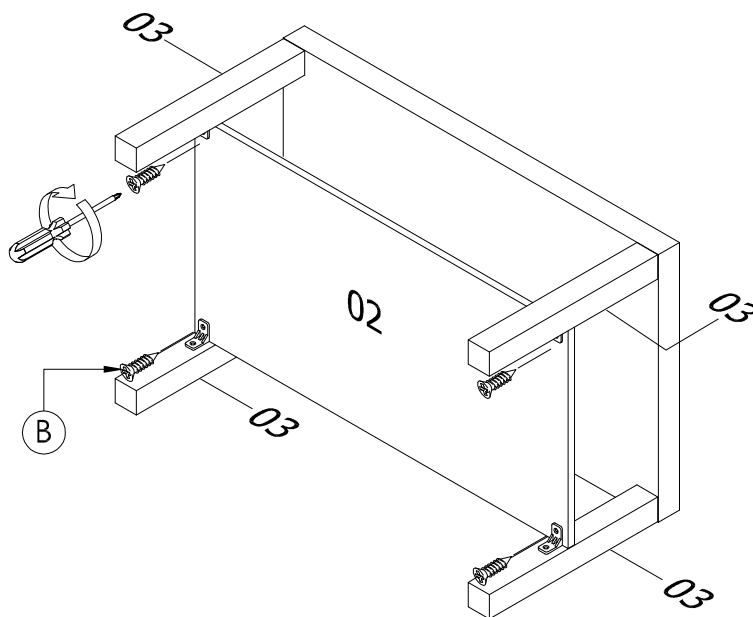
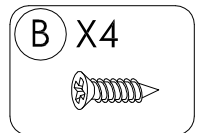

STEP 9:
ASSEMBLY IS COMPLETED

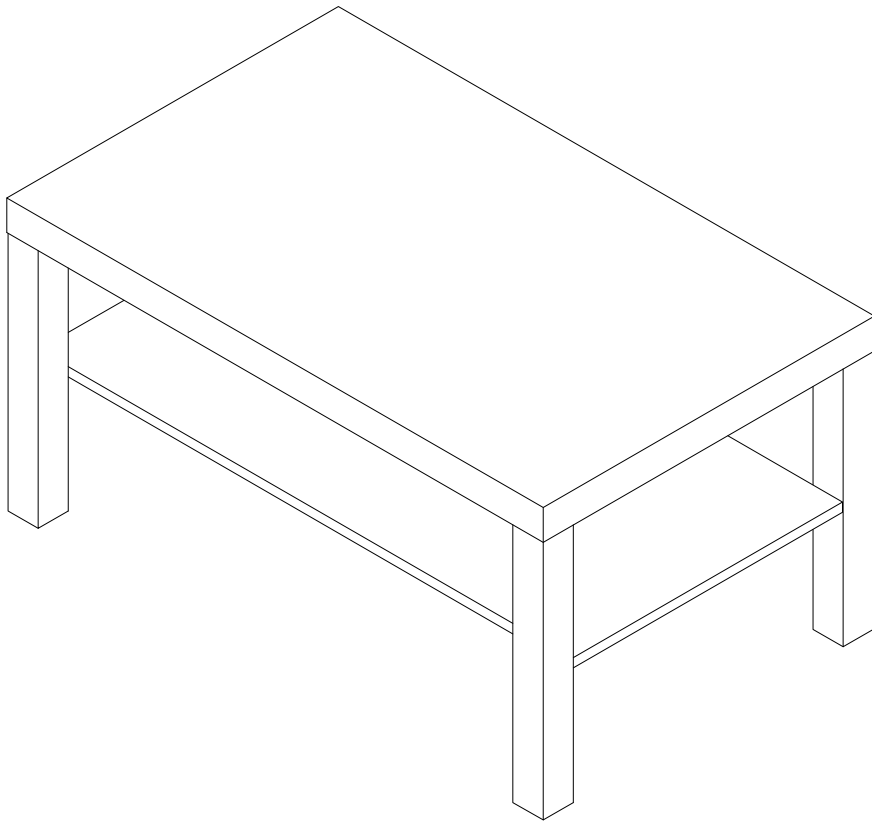

IMPORTANT: CARE GUIDE FOR YOUR HI-GLOSS FURNITURE

Congratulations! You have just purchased a quality product from Amart Furniture, Australia's largest discount furniture retail store. Please read on for important information regarding your purchase...

Hi-gloss lacquered furniture is more sensitive to marks and scratching than some other furniture products. It is important to exercise caution and care to maximise the life and beauty of this product.

Following the below simple guidelines when using your hi-gloss product will protect your investment for years to come:

Dust frequently with a clean damp , lint-free cloth. This will help remove abrasive build up which can damage a finish over time.

Avoid using chemicals or solvents when cleaning the product.

Do not place hot objects on any furniture surface. Always use a hot plate or placemat. Lacquer finishes provide added scratch and heat resistance to our furniture, but they can still be damaged without proper care.

Avoid exposing your furniture to strong sunlight. Prolonged exposure to direct sunlight can fade the finish of your furniture.

Do not expose your furniture to any liquids. Avoid allowing water to sit on your furniture. Alcohol, nail polish and perfume are particularly harmful as they will dissolve the lacquer finish on contact.

Do not allow plastic to come in direct contact with your furniture. Chemicals in the plastic of some placemats etc may soften and mark the finish if left in contact with the furniture for a period of time.

Avoid placing sharp or rough objects on the surface of your furniture. These may scratch the surface of the product.

When moving your furniture, do not drag it across the floor. This may damage the product. Instead use two people to lift carefully with caution from either end.

